

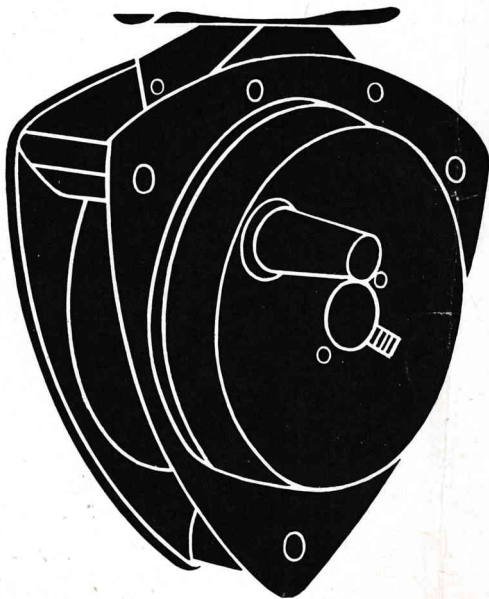

ABU DELTA 3



ABU
SVANGSTA

ABU DELTA 3

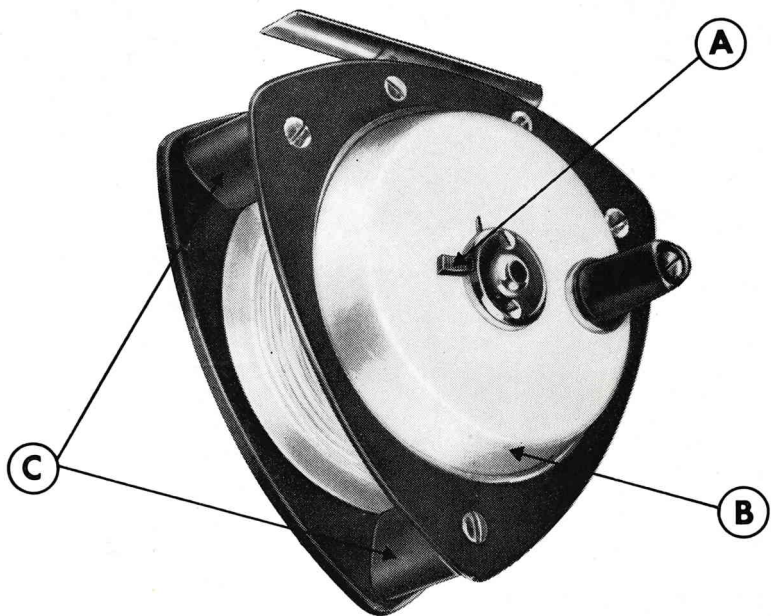

Tekniska finesser

- A Snabbt spolbyte
 - B Konisk bromstrumma — säkrare drillning
 - C Avrundade stag — inget linslitage
Hållbar och saltvatten-säker
-

Technical features

- A Quick removal of spool
 - B Conical brake drum — safer playing
 - C Broad, round pillars — no wear and tear of line
Sturdy and corrosion-proof
-

Teknisiä hienouksia

- A Nopea puolanvaihto
- B Puolassa kartiomainen jarrupinta — varmempi kalan väsyttäminen
- C Pyöristetetyt tukipilarit — ei siiman kulumista
Vankka rakenne ja suolavettä kestävä pintakäsittely

Technische Vorzüge

- A Schneller Spulenwechsel
 - B Konische Bremstrommel — sicheres Drillen
 - C Abgerundete Stützen — kein Schnurverschleiss
Haltbar und salzwasserbeständig
-

Caractéristiques techniques

- A Changement de bobine rapide
 - B Tambour de frein conique — sécurité de manoeuvre
 - C Piliers arrondis — aucune usure du nylon
Robuste et résistant à la corrosion marine
-

Distinciones técnicas

- A Cambio rápido del carrete
- B Tambor de freno, cónico — accionamiento más seguro
- C Vástagos redondeados — ningún desgaste del sedal
Duradero y resistente al agua del mar

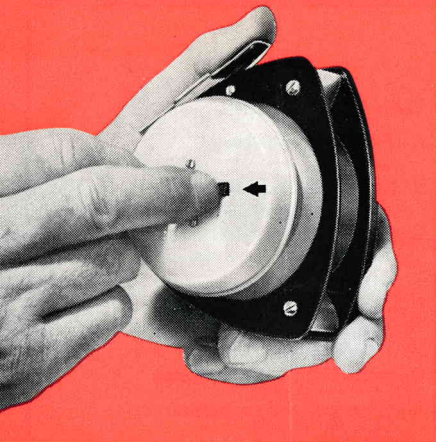

Spolbyte

Removal of spool

Puolan vaihto

Auswechseln der Spule

Changement de bobine

Cambio de bobina

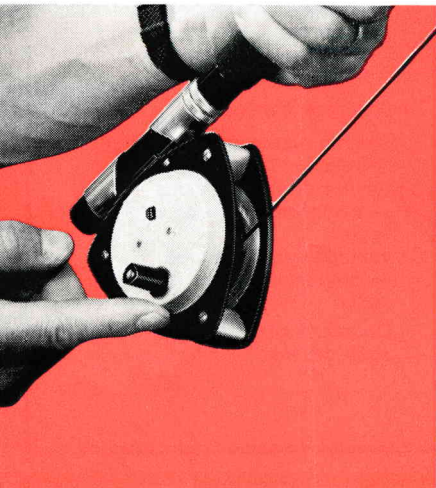

Fingerbromsning av linan

Finger tension control of
line

Siiman jarrutus sormella

Fingerbremsen der Schnur

Freinage de la ligne au
doigt

Freno dactilar del sedal

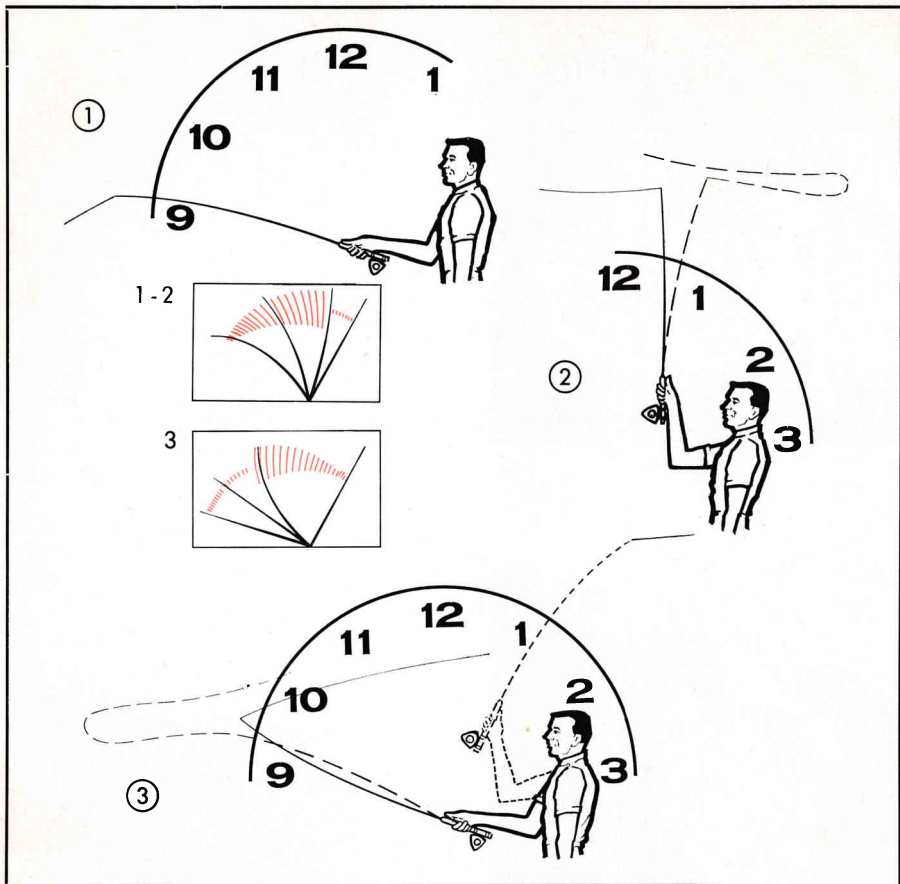

Kastet i en samman-
hängande rörelse

The cast in one continuous
movement

Heitto yhdellä ainoalla
liikkeellä

Der Wurf in einer zusam-
menhängenden Bewegung

Lancer d'un mouve-
ment souple et régulier

Lanzamiento con un
movimiento seguido

ABU DELTA 3

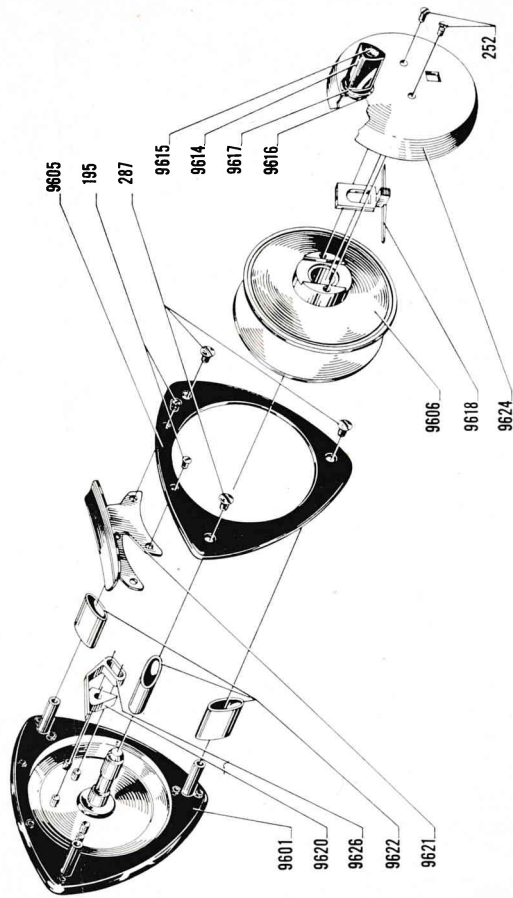

Fett
Grease
Rasvaa
Fett
Graisse
Grasa

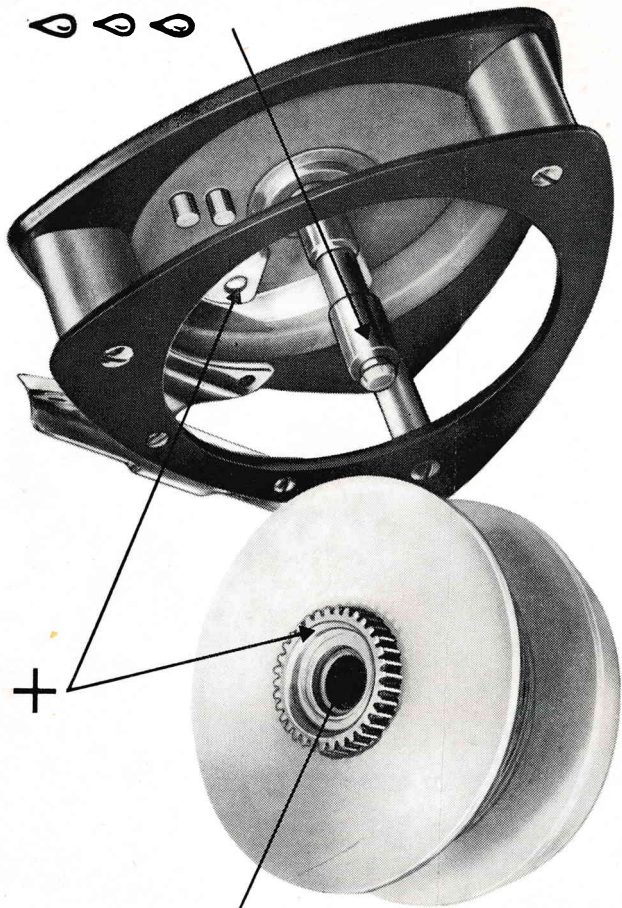

® ABU
SVÄNGSTA

AB URFABRIKEN
Svängsta - Sweden

